



IMAGE FUSION BASED ON CONTOURLET TRANSFORM AND DISCRETE WAVELET TRANSFORM

SK.NAJUNNEESA^{1*}, M.PRADEEP²

^{1*}PG Student, ECE Department, Indira Institute of Technology, Markapur

²Assistant Professor, ECE Department, Indira Institute of Technology, Markapur

Correspondence Author: naj0417@gmail.com

Keywords: Counterlet transform, directional filter bank, and DWT

Abstract

This paper proposes the image fusion based on counterlet transform and discrete wavelet transform. The DWT and CT transform are used to extract the best features from different blur input images. The images are portioned based on dimensional reduction methods such as Laplacian pyramid and different coefficients from discrete wavelet transform to enhance the mean square error (MSE) and peak signal to noise ratio (PSNR) for exhibit the good appearance of output image i.e. image fusion. Hybrid DWT architecture has the advantage of lowers computational complexities and higher efficiencies. The algorithm is written in system MATLAB software. Image fusion based on contourlet transform and discrete wavelet transform gives better MSE and PSNR results as compared to existing methods.

Introduction

Image fusion refers to the process of integrating information from different imaging modalities of a scene in a single composite image representation that is more informative and appropriate for visual perception or further processing [1]. The images considered for fusion may be the images of the same object taken at different time or by different sensors. The aim of image fusion is to combine complementary and redundant information from multiple images to create a faster interpretation of the images. By using redundant information, image fusion may improve accuracy as well as reliability and by using complementary information, image fusion may improve interpretation capabilities with respect to subsequent tasks. According to above characteristics, image fusion leads more accurate data, increased utility and robust performance. A large number of different image fusion methods have been proposed mainly due to the different available data types and various applications. A comprehensive survey of image fusion methods is available in [2], while a collection of papers was edited by Blum and Liu in [3]. For a dedicated review article on pixel based image fusion in remote sensing refer [4], where related techniques of Earth observation satellite data are presented as a contribution to multisensory integration- oriented data processing. Image fusion in the spatial domain [5]–[7] have gained significant interest mainly due to their simplicity and linearity. Multiresolution analysis is another popular approach for image fusion [8]–[10], using filters with increasing spatial level in order to produce a pyramid sequence of images at different resolutions. In most of these techniques the high saliency pyramid values are taken from the transformed image and their inverse transform is found to get the fused image. In the fields of remote sensing, fusion of multiband images that lie in different spectral bands and corresponding areas of the electromagnetic spectrum is one of the key areas of research. The main target in these techniques is to produce an effective representation of the combined multispectral image data, i.e., an application-oriented visualization in a reduced data set [11]–[14].

Basics concepts of contourlet transform (CT) and discrete wavelet transform (DWT) are discussed in section II. Proposed method is discussed in section III. Experimental results are presented in section IV. Concluding remarks are discussed in section V.

Contourlet transform & discrete wavelength transform

Contourlet transform (CT)

Jasiunas *et al.* [15] presented an image fusion system based on wavelet decomposition for unmanned airborne vehicles (UAVs). This is probably the first implementation developed on a reconfigurable platform alone, as well as the first investigation of adaptive image fusion that makes use of dynamic reconfiguration to change the fusion algorithm as the UAV approaches an object of interest. Results showed an achieved latency of 3.81 ms/frame for visible and infrared 8-bit images of 512×512 pixel resolution. Sims and Irvine presented in [16] an CONTOURLET implementation using pyramidal decomposition and subsequent fusion of dual video streams. In [17], a real-time image processing system was presented for combining the video outputs of an uncooled infrared imaging system and a low-level-light TV system. Both images were 384×288 in size, with 8-bit resolution. The hardware implementation was based on a simple weighted pixel average and provided poor results regarding the contrast of the fused images. Aiming to provide enhanced results in both visual effect and image quality, Song *et al.* [18] proposed an alternative image fusion implementation based on Laplacian pyramid decomposition of two-channel VGA video fusion using parallel and pipelined architectures. In their work, a three-level Laplacian pyramid image fusion algorithm was implemented in



MATLAB according to the designed methods (including controlling, decomposing, fusion, and reconstruction modules). The design was verified on a real-time dualchannel image fusion system based on Virtex-4 SX35 CONTOURLET, giving a fusion frame rate of 25 frames/s (realtime video). Li et al. [19] proposed an CONTOURLET system of multisensor image fusion and enhancement for visibility improvement that can be used to help drivers driving at night or under bad weather conditions. Their design included wavelet-decomposition-based image fusion, as well as image registration and enhancement in order to improve the visibility of roads in extremely low lightning conditions.

Discrete wavelet transform (DWT)

In this proposed system the hardware implementation of the DWT is performed. process as shown in figure

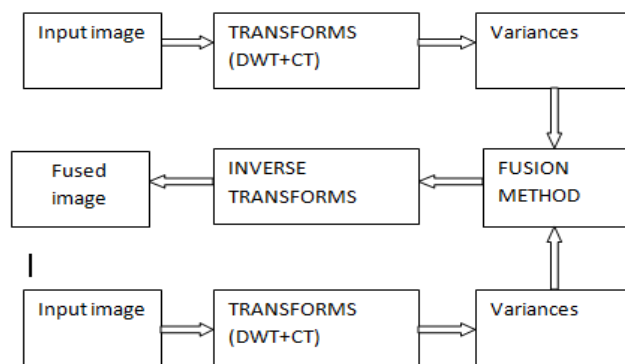

Figure: 1.Basic architecture

First, the DWT of images is taken. After that, the fusion process is carried out using appropriate fusion rule .Finally, the inverse DWT gives the final fused image.

Proposed method

Proposed Algorithm

Proposed method is presented below:

1. There are two images belonging to blur input image. Each face image is first partitioned into S equally sized, these sub-pattern images are transformed into corresponding column vectors with dimensions of $d = (A1 \times A2) / S$ using non-overlapping method.
2. In the first step decomposed the input images in discrete wavelet transform
3. Consider best feature vectors using DWT and calculate (MSE) mean square error value to minimize the error between two different images
4. Similarly same procedure for Laplacian pyramid method to enhance the peak signal to noise ration (PSNR) as well as (MSE) mean square error
5. Afterwards, S extracted local sub feature weights of an individual vertically are synthesized into a global feature.
6. Finally, the identification of the test image is done by using nearest neighbor classifier with differ transform measure then get good results as compared to existing methods

Experimental results

Experiments are performed on gray level images to verify the proposed method. These images are represented by 8 bits/pixel and size is 128 x 128. Image used for experiments are shown in below figure. The architectures were implemented in system C and placed and routed on Xilinx spartan3 XC3S200 CONTOURLET, using Xilinx platform studio v.10. Feature selection



Figure2: First image



Figure3: Second image

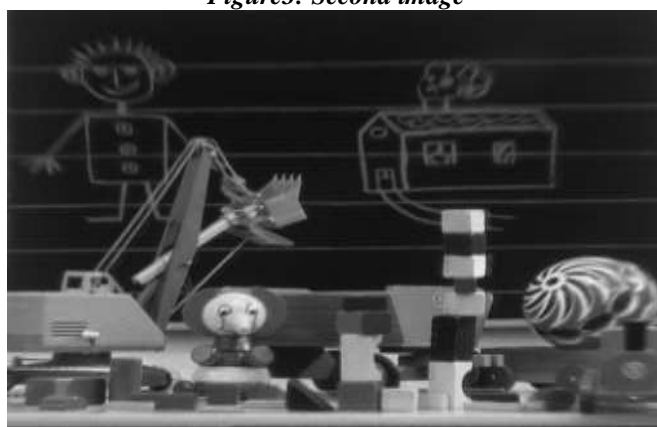

Figure4: Original image

A sample image from face database and by using sub-pattern technique it can be divided by equal parts. Feature of the query image size is (64×1) by using sub-pattern method. Some of the recognized results when all the 10 images ($N=10$) in one subject of the image database are recognized are shown in figure 3. From the query image feature is taken based on sub-pattern method. After that in this paper we take only 64 feature of this query image. That may be depends up on the sub-parts of this image ($S=16$). For each sub-pattern we consider four positive eigenvectors that is largest eigenvector of the subpart. It is represented as only local feature of the query image. After that combination of all sub-parts local feature it can be represented as global

feature of the query image. Comparative performance of all training global feature with this query image finally. The iamge recognition method take feature extraction technique as minimum as possible recognized results images with top left image as query image. Subpattern method and principal component analysis [8] can significantly improve the recognition accuracy of sub pattern vertically centered method. Since the vertical centering process centers the data by removing the mean of each image, it can be used to eliminate the effect of the values. In other words, the property of vertical centering process [9] can be helpful in eliminating the shifted values of original-pixels. Further, the sub-pattern technique can be utilized to encourage the efficiency of



the vertical centering process. Therefore, sub-pattern technique is actually useful to vertical centering process of sub-pattern technique. The vertical centering may benefits for the recognition in varying illumination. Now, we have confirmed this possible forecast and strongly increased the efficiency of the vertical centering process by sub-pattern technique in this paper. From the total experimental results, it can also be seen that for expression variant test, sub-pattern technique and Eigen vector can slightly improve weighted angle based approach classifier, the similarity between a test image and training image is defined as In the weighted angle based approach method cosine measurement.



Figure 4. Fusion image with MSE and PSNR

Average recognized rate

The average recognized rate for the query is measured by counting the number of images from the same category which are found in the top ‘N’ matches.

Table 1. MSE and PSNR for image fusion

Methods	MSE	PSNR (dB)
DWT Approximate method	19.34	35.26
Laplacian method (Contourlet)	12.36	37.2
HYBRID DWT method	9.09	38.54

Conclusion

This paper proposes the image fusion based on counterlet transform and discrete wavelet transform. The DWT and CT transform are used to extract the best features from different blur input images. The images are portioned based on dimensional reduction methods such as Laplacian pyramid and different coefficients from discrete wavelet transform to enhance the mean square error (MSE) and peak signal to noise ratio (PSNR) for exhibit the good appearance of output image i.e. image fusion. Hybrid DWT architecture has the advantage of lowers computational complexities and higher efficiencies. The algorithm is written in system



MATLAB software. Image fusion based on contourlet transform and discrete wavelet transform gives better MSE and PSNR results as compared to existing methods.

References

- [1] A. Goshtaby and S. Nikolov, "Image fusion: Advances in the state of the art," *Inf. Fusion*, vol. 8, no. 2, pp. 114–118, Apr. 2007.
- T. Stathaki, *Image Fusion: Algorithms and Applications*. New York: Academic, 2008.
- R. S. Blum and Z. Liu, Eds., *Multi-Sensor Image Fusion and Its Applications (Special Series on Signal Processing and Communications)*. New York: Taylor & Francis, 2006.
- C. Pohl and J. L. van Genderen, "Multisensor image fusion in remote sensing: Concepts, methods and applications," *Int. J. Remote Sens.*, vol. 19, no. 5, pp. 823–854, 1998.
- V. Tsagaris, V. Anastassopoulos, and G. Lampropoulos, "Fusion of hyperspectral data using segmented PCT for enhanced color representation," *IEEE Trans. Geosci. Remote Sens.*, vol. 43, no. 10, pp. 2365–2375, Oct. 2005.
- V. Tsagaris and V. Anastassopoulos, "Multispectral image fusion for improved RGB representation based on perceptual attributes," *Int. J. Remote Sens.*, vol. 26, no. 15, pp. 3241–3254, Aug. 2005.
- N. Jacobson, M. Gupta, and J. Cole, "Linear fusion of image sets for display," *IEEE Trans. Geosci. Remote Sens.*, vol. 45, no. 10, pp. 3277–3288, Oct. 2007.
- K. Nagarajan, C. Krekler, K. C. Slatton, and W. D. Graham, "A scalable approach to fusing spatiotemporal data to estimate streamflow via a Bayesian network," *IEEE Trans. Geosci. Remote Sens.*, vol. 48, no. 10, pp. 3720–3732, Oct. 2010.
- G. Piella, "A general framework for multiresolution image fusion: From pixels to regions," *Inf. Fusion*, vol. 4, no. 4, pp. 259–280, Dec. 2003.
- C. Thomas, T. Ranchin, L. Wald, and J. Chanussot, "Synthesis of multispectral images to high spatial resolution: A critical review of fusion methods based on remote sensing physics," *IEEE Trans. Geosci. Remote Sens.*, vol. 46, no. 5, pp. 1301–1312, May 2008.
- J. Tyo, A. Konsolakis, D. Diersen, and R. C. Olsen, "Principal components-based display strategy for spectral imagery," *IEEE Trans. Geosci. Remote Sens.*, vol. 41, no. 3, pp. 708–718, Mar. 2003.
- W. Zhang and J. Kang, "QuickBird panchromatic and multi-spectral image fusion using wavelet packet transform," in *Lecture Notes in Control and Information Sciences*, vol. 344. Berlin, Germany: Springer-Verlag, 2006, pp. 976–981.
- V. Shah, N. Younan, and R. King, "An efficient pansharpening method via a combined adaptive PCA approach and contourlets," *IEEE Trans. Geosci. Remote Sens.*, vol. 46, no. 5, pp. 1323–1335, May 2008...
- K. Kotwal and S. Chaudhuri, "Visualization of hyperspectral images using bilateral filtering," *IEEE Trans. Geosci. Remote Sens.*, vol. 48, no. 5, pp. 2308–2316, May 2010.
- M. D. Jasiunas, D. A. Kearney, J. Hopf, and G. B. Wigley, "Image fusion for uninhabited airborne vehicles," in *Proc. Int. Conf. FPT*, Dec. 16–18, 2002, pp. 348–351.
- O. Sims and J. Irvine, "An FPGA implementation of pattern-selective pyramidal image fusion," in *Proc. Int. Conf. FPL*, Aug. 28–30, 2006, pp. 1–4.
- Q. Yunsheng, Z. Junju, T. Shi, C. Qian, Z. Zixiang, and C. Benkang, "The real-time processing system of infrared and LLL image fusion," in *Proc. Int. Symp. Photoelectron. Detection Imag.: Image Process.*, Mar. 2008, pp. 66 231Y-1–66 231Y-9.
- Y. Song, K. Gao, G. Ni, and R. Lu, "Implementation of real-time Laplacian pyramid image fusion processing based on FPGA," in *Proc. SPIE*, 2007, vol. 6833, pp. 683 316–683 318.
- T. Li, N. Hau, Z. Ming, A. Livingston, and V. Asari, "Multisensor image fusion and enhancement system for assisting drivers in poor lighting conditions," in *Proc. 34th Appl. Imag. Pattern Recognit. Workshop*, 2005, pp. 106–113.
- B.-S. Kong, S.-S. Kim, and Y.-H. Jun, "Conditional-capture lip-flop for statistical power reduction," *IEEE J. Solid-State Circuits*, vol. 36, no. 8, pp. 1263–1271, Aug. 2001.
- H. Jacobson, P. Bose, Z. Hu, A. Buyuktosunoglu, V. Zyuban, R. Eickemeyer, L. Eisen, J. Griswell, D. Logan, B. Sinharoy, and J. Tendler, "Stretching the limits of clock-gating efficiency in server-class processors," in *Proc. Int. Symp. High-Perform. Comput. Archit.*, Feb. 2005, pp. 238–242.
- W. Aloisi and R. Mita, "Gated-clock design of linear-feedback shift registers," *IEEE Trans. Circuits Syst. II, Exp. Briefs*, vol. 55, no. 6, pp. 546–550, Jun. 2008.
- J. M. Labaey and M. Pedram, *Reduce Power Design Methodologies*. Norwell, MA: Kluwer, 1996, ch. 3. [12] G. Gerosa, S. Gary, C. Dietz, D. Pham, K. Hoover, J. Alvarez, H. Sanchez, P. Ippolito, T. Ngo, S. Litch, J. Eno, J. Golab, N. Vanderschaaf, and J. Kahle, "A 2.2 W 80 MHz superscalar RISC microprocessor," *IEEE J. Solid-State Circuits*, vol. 29, no. 12, pp. 1440–1452, Dec. 1994.



INTERNATIONAL JOURNAL OF RESEARCH SCIENCE & MANAGEMENT

24. H. Partovi, R. Burd, U. Salim, F. Weber, L. DiGregorio, and D. Draper, "Freduce-through latch and edge-triggered flip-flop hybrid elements," in Proc. IEEE Int. Solid-State Circuits Conf., Feb. 1996, pp.138–139.